

ARFET
BUS SHELTER
GRANAT

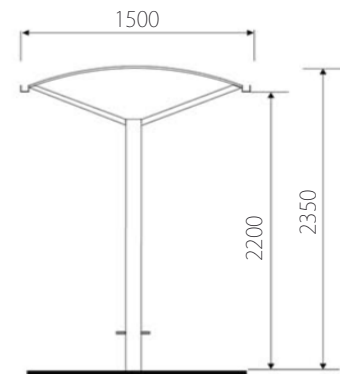

ARRET

BUS SHELTER GRANAT

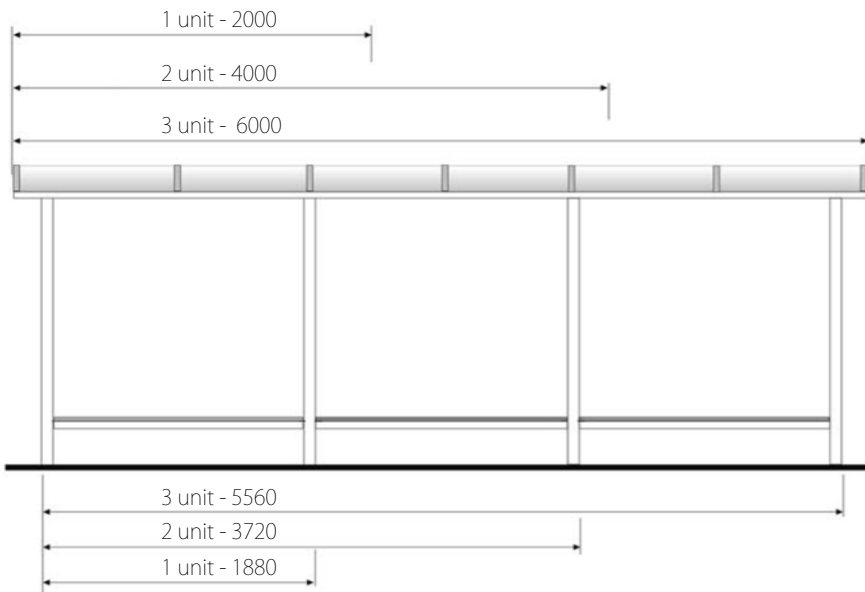

Construction:

Shelter made of steel rectangle or square profile section, hot dip galvanized acc. to ISO EN 1461 and electrostatical powder painted acc. to each color of RAL Standard palette

Models and Dimensions:

Available in 3 different length depending on the amount of units:

- model 101- 1 unit
- model 102 - 2 units
- model 103 - 3 units

Types of infills:

Roof - 6mm polycarbonate sheet, dimmed,
Shelter without side and back walls infill.

Seating bench:

Shelter is offered with 3 types of seats:

- bench with wooden planks (standard)
- bench with laminated planks (optional)
- individual injected moulded plastic seats (optional).

Back support over the seating bench:

Shelter without back support.

Optional equipment:

- informational display case with lock, dimensions 1260 x 700mm or 700 x 700mm
- bus stop sign
- name of the bus stop
- recycled waste bin (freestanding or assembled to the shelter construction)
- bus driving schedule in format A4, A3 or A2.